

# J-Hanger

## Product Features

- Size Range: 1½" through 6"
- Material: Carbon steel
- Finish: Galvanized
- Components: Strap and bolt with nut – assembled.

## Certifications

- Approvals: Complies with Federal Specification A-A-1192A (Type 5), ANSI/MSS SP-69 and MSS SP-58 (Type 5).

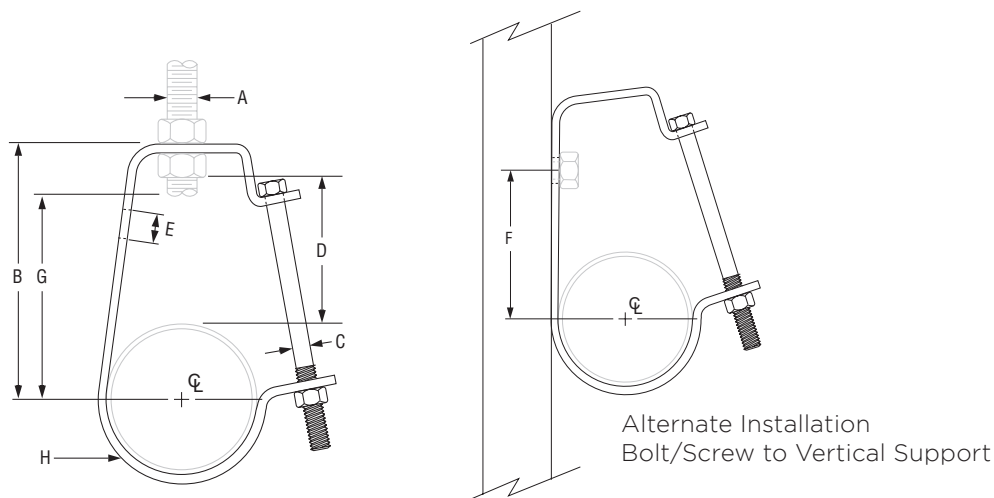

## J-Hanger: Loads (LBS) • Weights (LBS) • Dimensions (IN)

Size	✓ To Submit	Part No. Plain	Max Load	Weight	A Rod Size	B	C	D	E	F	G	H Width
1½"		ML37221	400	0.29	3/8	3 <sup>9</sup> / <sub>16</sub>	1/4	2 <sup>3</sup> / <sub>16</sub>	7/16	2 <sup>7</sup> / <sub>16</sub>	2 <sup>7</sup> / <sub>8</sub>	1
2"		ML37222	400	0.31	3/8	3 <sup>11</sup> / <sub>16</sub>	1/4	2 <sup>1</sup> / <sub>8</sub>	7/16	2 <sup>9</sup> / <sub>16</sub>	3 <sup>1</sup> / <sub>16</sub>	1
3"		ML37223	500	0.78	1/2	4 <sup>13</sup> / <sub>16</sub>	3/8	2 <sup>9</sup> / <sub>16</sub>	9/16	3 <sup>1</sup> / <sub>2</sub>	4 <sup>1</sup> / <sub>16</sub>	1¼
4"		ML37224	550	1.39	5/8	6 <sup>1</sup> / <sub>8</sub>	3/8	3 <sup>3</sup> / <sub>16</sub>	9/16	4 <sup>5</sup> / <sub>8</sub>	5 <sup>3</sup> / <sub>16</sub>	1¼
6"		ML37225	600	2.26	3/4	7 <sup>3</sup> / <sub>4</sub>	3/8	3 <sup>9</sup> / <sub>16</sub>	9/16	5 <sup>13</sup> / <sub>16</sub>	6 <sup>5</sup> / <sub>8</sub>	1¼

## Warranty

See warranty information for more details

All dimensions listed are nominal. MAINLINE® reserves the right to make product and material changes at any time without notice.

