

1⁵/₈" x 1⁵/₈" Strut - 12 Gauge

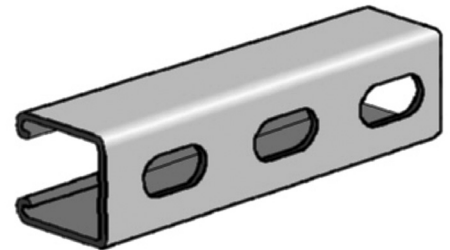

Product Features

- Size: 1⁵/₈" x 1⁵/₈", 12 Gauge channel wt./100 ft. - 189 lbs.
- Material: Carbon steel - High quality structural steel in accordance with ASTM A-570 Grade 33 (Hot rolled) or ASTM 366 (Cold rolled)
- Finish: Pre-Galvanized or Green Powdered Coated
- Style: Slotted Holes: 9/16" x 1/8", 2" on Centers

Weights (LBS) • Dimensions (IN)

Description	Gauge	Style	✓ To Submit	Part No. Pre-Galv.	Part No. Green	✓ To Submit	Standard Packaging (FT)	Weight per 100 FT
1 ⁵ / ₈ x 1 ⁵ / ₈ x 10'	12 GA.	Slotted		ML37305	ML37309		500	189
1 ⁵ / ₈ x 1 ⁵ / ₈ x 20'	12 GA.	Slotted		ML37304	ML37308		500	189

Warranty

See warranty information for more details



All dimensions listed are nominal. MAINLINE® reserves the right to make product and material changes at any time without notice.



1⁵/₈" x 1⁵/₈" Strut - 12 Gauge

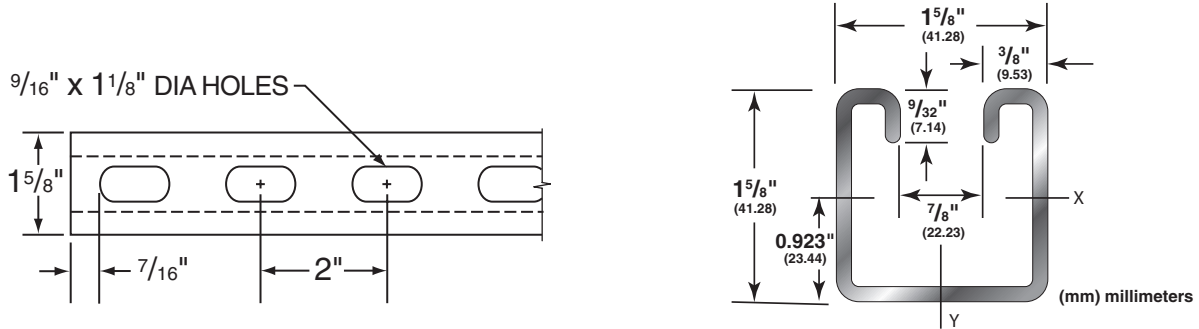

Properties of Section (Without Holes)

I = Moment of Inertia S = Section Modulus r = Radius of Gyration

Wt./Ft.		Area of Section		X-X Axis						Y-Y Axis					
Lbs	kg	Sq. In.	Sq. Cm.	I in ⁴	I cm ⁴	S in ³	S cm ³	r in	r cm	I in ⁴	I cm ⁴	S in ³	S cm ³	r in	r cm
1.95	0.88	0.544	3.510	0.180	7.492	0.195	3.195	0.575	1.461	0.233	9.698	0.287	4.703	0.655	1.664

Beam and Column Loads

Span or Column		Max Load of Column Loaded @ C.G.		Static Beam Load (X-X Axis)							
				Allowable Uniform Load @ 25,000 PSI (1758 Kg/cm ²)		Deflection @ 25,000 PSI (1758 Kg/cm ²)		Uniform Load @ 1/240		Uniform Load @ 1/360	
In	mm	Lbs	kg	Lbs	kg	In	mm	Lbs	kg	Lbs	kg
12	305	7,109	3,225	3,249	1,474	0.014	0.356	**	**	**	**
18	457	6,549	2,971	2,166	982	0.031	0.787	**	**	**	**
24	610	5,938	2,693	1,625	737	0.055	1.397	**	**	**	**
30	762	5,337	2,421	1,300	590	0.086	2.184	**	**	1,257	570
36	914	4,771	2,164	1,083	481	0.124	3.150	**	**	873	396
42	1,067	4,242	1,924	928	421	0.169	4.293	**	**	641	291
48	1,219	3,745	1,699	812	368	0.220	5.588	737	334	491	223
60	1,524	3,012	1,366	650	295	0.344	8.738	471	214	314	142
72	1,829	2,514	1,140	542	246	0.496	12.598	327	148	218	99
84	2,134	2,136	969	464	210	0.675	17.145	240	109	160	73
96	2,438	1,834	832	406	184	0.882	22.403	184	83	123	56
108	2,743	1,585	719	361	164	1.116	28.346	145	66	97	44
120	3,048	*	*	325	147	1.378	35.001	117	53	78	35
180	4,572	*	*	217	98	3.099	78.715	52	24	35	16
240	6,096	*	*	163	74	5.510	139.954	29	13	19	9

- Notes: 1. The beam capacities shown above include the weight of the strut beam. The beam weight must be subtracted from these capacities to arrive at the net beam capacity.
 2. Allowable beam loads are based on a uniformly loaded, simply supported beam. When calculating concentrated load at center of span, multiply uniform load table by .5 and deflection by .8
 3. The load chart shows beam capacities for strut without holes. For strut with slotted holes multiply by .88
 * Not recommended kl/r exceeds 200
 ** For these loads, the uniform beam capacity is lower than 1/240 or 1/360 beam capacities and is therefore the governing constraint.

All dimensions listed are nominal. MAINLINE® reserves the right to make product and material changes at any time without notice.



1⁵/₈" x 1⁵/₈" Strut - 14 Gauge

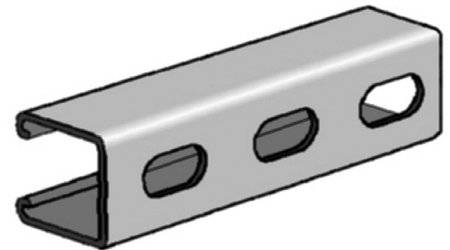

Product Features

- Size: 1⁵/₈" x 1⁵/₈", 14 Gauge channel wt./100 ft. - 140 lbs.
- Material: Carbon steel - High quality structural steel in accordance with ASTM A-570 Grade 33 (Hot rolled) or ASTM 366 (Cold rolled)
- Finish: Pre-Galvanized
- Style: Slotted Holes: 9/16" x 1/8", 2" on Centers

Weights (LBS) • Dimensions (IN)

Description	Gauge	Style	✓ To Submit	Part No. Pre-Galv.	Standard Packaging (FT)	Weight per 100 FT
1 ⁵ / ₈ x 1 ⁵ / ₈ x 10'	14 GA.	Slotted		ML37307	500	140
1 ⁵ / ₈ x 1 ⁵ / ₈ x 20'	14 GA.	Slotted		ML37306	500	140

Warranty

See warranty information for more details



All dimensions listed are nominal. MAINLINE® reserves the right to make product and material changes at any time without notice.



1⁵/₈" x 1⁵/₈" Strut - 14 Gauge

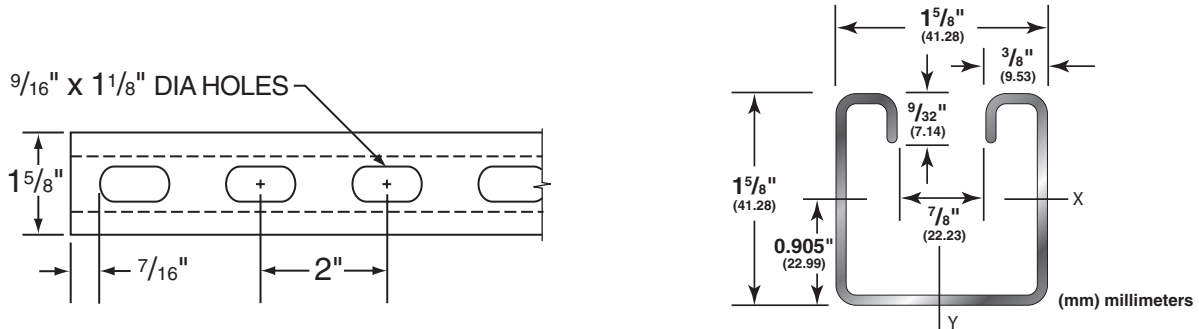

Properties of Section (Without Holes)

I = Moment of Inertia S = Section Modulus r = Radius of Gyration

Wt./Ft.		Area of Section		X-X Axis						Y-Y Axis					
Lbs	kg	Sq. In.	Sq. Cm.	I in ⁴	I cm ⁴	S in ³	S cm ³	r in	r cm	I in ⁴	I cm ⁴	S in ³	S cm ³	r in	r cm
1.45	0.66	0.407	2.626	0.143	5.952	0.158	2.589	0.593	1.506	0.179	7.451	0.221	3.622	0.664	1.687

Beam and Column Loads

Span or Column		Max Load of Column Loaded @ C.G.		Static Beam Load (X-X Axis)							
				Allowable Uniform Load @ 25,000 PSI (1758 Kg/cm ²)		Deflection @ 25,000 PSI (1758 Kg/cm ²)		Uniform Load @ 1/240		Uniform Load @ 1/360	
In	mm	Lbs	kg	Lbs	kg	In	mm	Lbs	kg	Lbs	kg
12	305	5,548	2,517	2,631	1,193	0.014	0.356	**	**	**	**
18	457	5,066	2,298	1,754	796	0.032	0.813	**	**	**	**
24	610	4,473	2,029	1,316	597	0.056	1.422	**	**	**	**
30	762	3,817	1,731	1,052	477	0.088	2.235	**	**	1,001	454
36	914	3,141	1,425	877	398	0.126	3.200	**	**	695	315
42	1,067	2,546	1,155	752	341	0.172	4.369	**	**	511	232
48	1,219	2,148	974	658	298	0.224	5.690	587	266	391	177
60	1,524	1,659	753	526	239	0.350	8.890	376	171	250	113
72	1,829	1,370	621	439	199	0.504	12.802	261	118	174	79
84	2,134	1,174	533	376	171	0.687	17.450	192	87	128	58
96	2,438	1,028	466	329	149	0.897	22.784	147	67	98	44
108	2,743	911	413	292	132	1.135	28.829	116	53	77	35
120	3,048	*	*	263	119	1.401	35.585	94	43	63	29
180	4,572	*	*	175	79	3.153	80.086	42	19	28	13
240	6,096	*	*	132	60	5.605	142.367	23	10	16	7

- Notes: 1. The beam capacities shown above include the weight of the strut beam. The beam weight must be subtracted from these capacities to arrive at the net beam capacity.
 2. Allowable beam loads are based on a uniformly loaded, simply supported beam. When calculating concentrated load at center of span, multiply uniform load table by .5 and deflection by .8
 3. The load chart shows beam capacities for strut without holes. For strut with slotted holes multiply by .88
 * Not recommended kl/r exceeds 200
 ** For these loads, the uniform beam capacity is lower than 1/240 or 1/360 beam capacities and is therefore the governing constraint.

All dimensions listed are nominal. MAINLINE® reserves the right to make product and material changes at any time without notice.



13/16" x 15/8" Strut - 12 Gauge

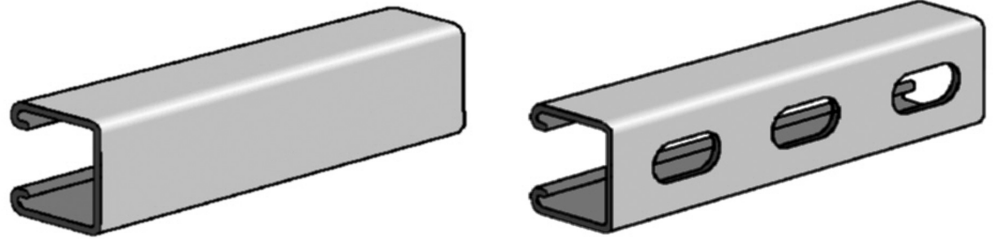

Product Features

- Size: 13/16" x 15/8", 12 Gauge channel wt./100 ft. - 135 lbs.
- Material: Carbon steel - High quality structural steel in accordance with ASTM A-570 Grade 33 (Hot rolled) or ASTM 366 (Cold rolled)
- Finish: Pre-Galvanized
- Style: Solid or Slotted Holes: 9/16" x 11/8", 2" on Centers

Weights (LBS) • Dimensions (IN)

Description	Gauge	Style	✓ To Submit	Part No. Pre-Galv.	Standard Packaging (FT)	Weight per 100 FT
13/16 x 15/8 x 20'	12 GA.	Solid		ML37318	500	135
13/16 x 15/8 x 20'	12 GA.	Slotted		ML37310	500	130

Warranty

See warranty information for more details



All dimensions listed are nominal. MAINLINE® reserves the right to make product and material changes at any time without notice.



13/16" x 15/8" Strut - 12 Gauge

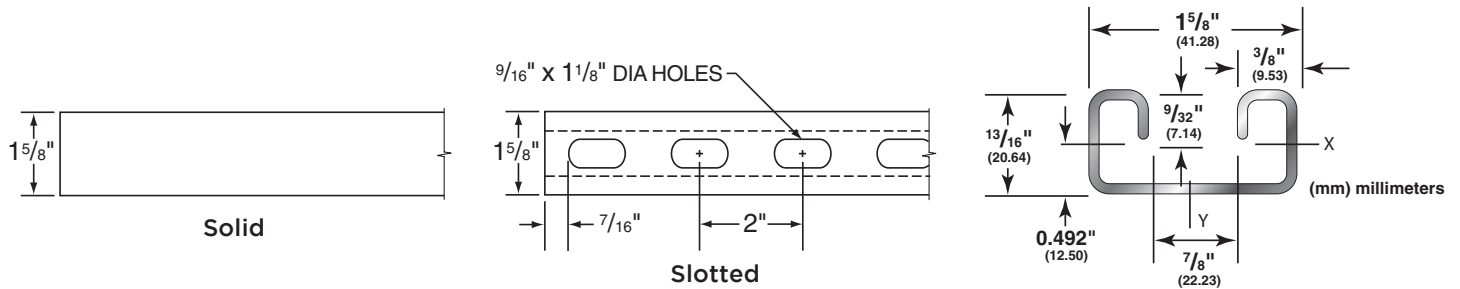

Properties of Section

I = Moment of Inertia S = Section Modulus r = Radius of Gyration

Wt./Ft.		Area of Section		X-X Axis						Y-Y Axis					
Lbs	kg	Sq. In.	Sq. Cm.	I in ⁴	I cm ⁴	S in ³	S cm ³	r in	r cm	I in ⁴	I cm ⁴	S in ³	S cm ³	r in	r cm
1.374	0.623	0.374	2.413	0.030	1.249	0.062	1.016	0.283	0.719	0.135	5.619	0.166	2.720	0.600	1.524

Beam and Column Loads

Span or Column		Max Load of Column Loaded @ C.G.		Static Beam Load (X-X Axis)							
				Allowable Uniform Load @ 25,000 PSI (1758 Kg/cm ²)		Deflection @ 25,000 PSI (1758 Kg/cm ²)		Uniform Load @ 1/240		Uniform Load @ 1/360	
				In	mm	Lbs	kg	In	mm	Lbs	kg
12	305	4,423	2,006	1,025	465	0.026	0.660	**	**	**	**
18	457	4,214	1,911	683	310	0.059	1.499	**	**	581	264
24	610	4,039	1,832	513	233	0.105	2.667	490	222	327	148
30	762	3,882	1,761	410	186	0.163	4.140	313	142	209	95
36	914	3,727	1,691	342	155	0.235	5.969	218	99	145	66
42	1,067	3,558	1,614	293	133	0.320	8.128	160	73	107	49
48	1,219	3,369	1,528	256	116	0.419	10.643	122	55	81	37
60	1,524	*	*	205	93	0.654	16.612	78	35	52	24
72	1,829	*	*	171	78	0.941	23.901	54	24	36	16
84	2,134	*	*	146	66	1.282	32.563	40	18	27	12
96	2,438	*	*	128	58	1.674	42.520	31	14	21	10
108	2,743	*	*	114	52	2.119	53.823	24	11	16	7
120	3,048	*	*	103	47	2.616	66.446	20	9	13	6
180	4,572	*	*	68	31	5.887	149.530	9	4	6	3
240	6,096	*	*	51	23	10.465	265.811	5	2	3	1

- Notes: 1. The beam capacities shown above include the weight of the strut beam. The beam weight must be subtracted from these capacities to arrive at the net beam capacity.
 2. Allowable beam loads are based on a uniformly loaded, simply supported beam. When calculating concentrated load at center of span, multiply uniform load table by .5 and deflection by .8
 3. The load chart shows beam capacities for strut without holes. For strut with slotted holes multiply by .88
 * Not recommended kl/r exceeds 200
 ** For these loads, the uniform beam capacity is lower than 1/240 or 1/360 beam capacities and is therefore the governing constraint.

All dimensions listed are nominal. MAINLINE® reserves the right to make product and material changes at any time without notice.



13/16" x 15/8" Strut - 14 Gauge

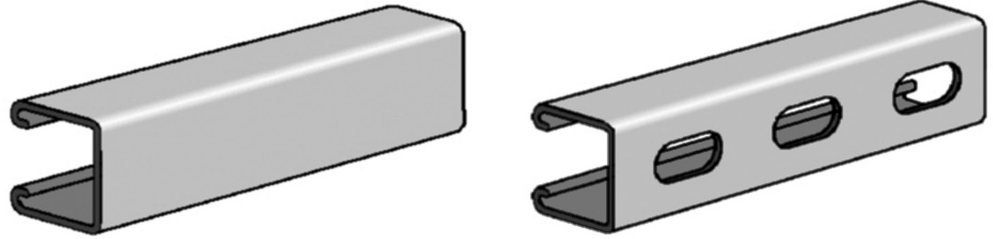

Product Features

- Size: 13/16" x 15/8", 14 Gauge channel wt./100 ft. - 103 lbs.
- Material: Carbon steel - High quality structural steel in accordance with ASTM A-570 Grade 33 (Hot rolled) or ASTM 366 (Cold rolled)
- Finish: Plain, Pre-Galvanized and Green Powdered Coated
- Style: Solid or Slotted Holes: 9/16" x 1/8", 2" on Centers

Weights (LBS) • Dimensions (IN)

Description	Gauge	Style	✓ To Submit	Part No. Plain	✓ To Submit	Part No. Pre-Galv.	✓ To Submit	Part No. Green	Standard Packaging (FT)	Weight per 100 FT
13/16 x 15/8 x 20'	14 GA.	Solid		-		ML37317		-	500	103
13/16 x 15/8 x 10'	14 GA.	Slotted		ML37315		ML37312		ML37314	500	98
13/16 x 15/8 x 20'	14 GA.	Slotted		-		ML37311		ML37313	500	98

Warranty

See warranty information for more details



All dimensions listed are nominal. MAINLINE® reserves the right to make product and material changes at any time without notice.



13/16" x 15/8" Strut - 14 Gauge

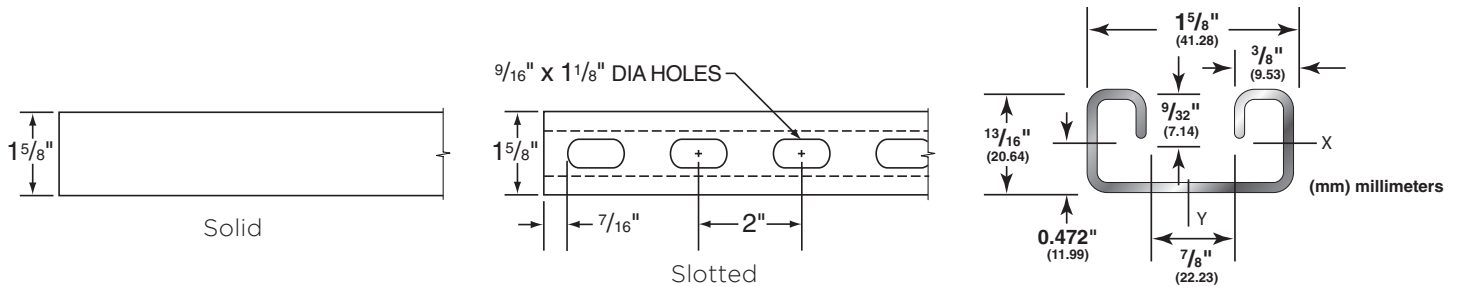

Properties of Section

I = Moment of Inertia S = Section Modulus r = Radius of Gyration

Wt./Ft.		Area of Section		X-X Axis						Y-Y Axis					
Lbs	kg	Sq. In.	Sq. Cm.	I in ⁴	I cm ⁴	S in ³	S cm ³	r in	r cm	I in ⁴	I cm ⁴	S in ³	S cm ³	r in	r cm
1.03	0.47	0.286	1.845	0.025	1.041	0.053	0.869	0.298	0.757	0.106	4.412	0.131	2.147	0.610	1.549

Beam and Column Loads

Span or Column		Max Load of Column Loaded @ C.G.		Static Beam Load (X-X Axis)							
				Allowable Uniform Load @ 25,000 PSI (1758 Kg/cm ²)		Deflection @ 25,000 PSI (1758 Kg/cm ²)		Uniform Load @ 1/240		Uniform Load @ 1/360	
				Lbs	kg	In	mm	Lbs	kg	Lbs	kg
12	305	3,598	1,632	887	402	0.027	0.686	**	**	**	**
18	457	3,340	1,515	591	268	0.060	1.524	**	**	493	224
24	610	3,086	1,400	444	201	0.106	2.692	416	189	277	126
30	762	2,854	1,295	355	161	0.166	4.216	266	121	177	80
36	914	2,645	1,200	296	134	0.240	6.096	185	84	123	56
42	1,067	2,449	1,111	254	115	0.327	8.306	136	62	91	41
48	1,219	2,259	1,025	222	101	0.427	10.846	104	47	69	31
60	1,524	*	*	177	80	0.667	16.942	66	30	44	20
72	1,829	*	*	148	67	0.960	24.384	46	21	31	14
84	2,134	*	*	127	58	1.037	26.340	34	15	23	10
96	2,438	*	*	111	50	1.707	43.358	26	12	17	8
108	2,743	*	*	99	45	2.160	54.864	21	10	14	6
120	3,048	*	*	89	40	2.668	67.767	17	8	11	5
180	4,572	*	*	59	27	6.003	152.476	7	3	5	2
240	6,096	*	*	44	20	10.672	271.069	4	2	3	1

- Notes: 1. The beam capacities shown above include the weight of the strut beam. The beam weight must be subtracted from these capacities to arrive at the net beam capacity.
 2. Allowable beam loads are based on a uniformly loaded, simply supported beam. When calculating concentrated load at center of span, multiply uniform load table by .5 and deflection by .8
 3. The load chart shows beam capacities for strut without holes. For strut with slotted holes multiply by .88
 * Not recommended k/l/r exceeds 200
 ** For these loads, the uniform beam capacity is lower than 1/240 or 1/360 beam capacities and is therefore the governing constraint.

All dimensions listed are nominal. MAINLINE® reserves the right to make product and material changes at any time without notice.



1⁵/₈" x 3¹/₄" Back-To-Back Strut - 12 Gauge

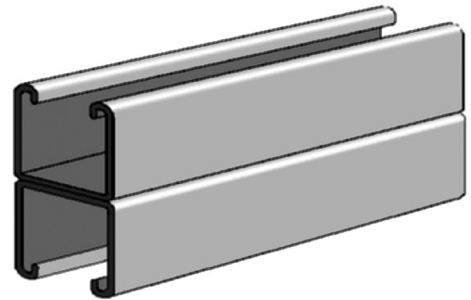

Product Features

- Size: 1⁵/₈" x 3¹/₄", 12 Gauge channel wt./100 ft. - 370 lbs.
- Material: Carbon steel - High quality structural steel in accordance with ASTM A-570 Grade 33 (Hot rolled) or ASTM 366 (Cold rolled)
- Finish: Pre-Galvanized
- Style: Slotted Holes: 9/16" x 1/8", 2" on Centers

Weights (LBS) • Dimensions (IN)

Description	Gauge	Style	✓ To Submit	Part No. Pre-Galv.	Standard Packaging (FT)	Weight per 100 FT
1 ⁵ / ₈ x 3 ¹ / ₄ x 20'	12 GA.	Slotted		ML37316	300	370

Warranty

See warranty information for more details



All dimensions listed are nominal. MAINLINE® reserves the right to make product and material changes at any time without notice.



1⁵/₈" x 3¹/₄" Back-To-Back Strut - 12 Gauge

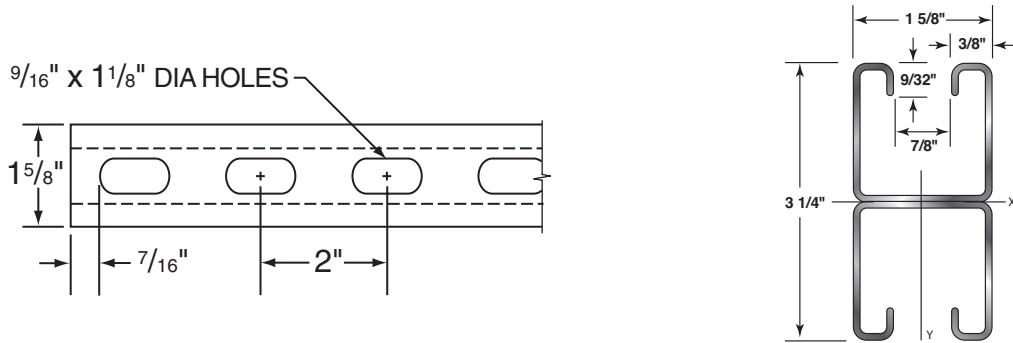

Properties of Section (Without Holes)

I = Moment of Inertia S = Section Modulus r = Radius of Gyration

Wt./Ft.		Area of Section		X-X Axis						Y-Y Axis					
Lbs	kg	Sq. In.	Sq. Cm.	I in ⁴	I cm ⁴	S in ³	S cm ³	r in	r cm	I in ⁴	I cm ⁴	S in ³	S cm ³	r in	r cm
3.88	1.76	1.088	7.019	0.896	37.294	0.570	9.341	0.908	2.306	0.466	19.396	0.574	9.406	0.655	1.664

Beam and Column Loads

Span or Column		Max Load of Column Loaded @ C.G.		Static Beam Load (X-X Axis)							
				Allowable Uniform Load @ 25,000 PSI (1758 Kg/cm ²)		Deflection @ 25,000 PSI (1758 Kg/cm ²)		Uniform Load @ 1/240		Uniform Load @ 1/360	
In	mm	Lbs	kg	Lbs	kg	In	mm	Lbs	kg	Lbs	kg
12	305	14,862	6,741	2,610 ***	1,184	0.008	0.203	**	**	**	**
18	457	14,402	6,533	2,610 ***	1,184	0.018	0.457	**	**	**	**
24	610	13,919	6,314	2,610 ***	1,184	0.032	0.813	**	**	**	**
30	762	13,473	6,111	2,610 ***	1,184	0.050	1.270	**	**	**	**
36	914	13,090	5,938	2,610 ***	1,184	0.072	1.829	**	**	**	**
42	1,067	12,771	5,793	2,610 ***	1,184	0.099	2.515	**	**	**	**
48	1,219	12,511	5,675	2,610 ***	1,184	0.129	3.277	**	**	**	**
60	1,524	11,685	5,300	1,899	861	0.202	5.131	**	**	1,566	710
72	1,829	10,078	4,571	1,582	718	0.291	7.391	**	**	1,087	493
84	2,134	8,180	3,710	1,356	615	0.396	10.058	1,199	544	799	362
96	2,438	6,291	2,854	1,187	538	0.517	13.132	917	416	611	277
108	2,743	4,971	2,255	1,055	479	0.655	16.657	725	329	483	219
120	3,048	4,026	1,826	949	430	0.808	20.523	587	266	391	177
180	4,572	*	*	633	287	1.819	46.203	261	118	174	79
240	6,096	*	*	474	215	3.233	82.118	147	67	98	44

- Notes: 1. The beam capacities shown above include the weight of the strut beam. The beam weight must be subtracted from these capacities to arrive at the net beam capacity.
 2. Allowable beam loads are based on a uniformly loaded, simply supported beam. When calculating concentrated load at center of span, multiply uniform load table by .5 and deflection by .8
 3. The load chart shows beam capacities for strut without holes. For strut with slotted holes multiply by .88
 * Not recommended kl/r exceeds 200
 ** For these loads, the uniform beam capacity is lower than 1/240 or 1/360 beam capacities and is therefore the governing constraint.
 *** Load limited by spotweld shear

All dimensions listed are nominal. MAINLINE® reserves the right to make product and material changes at any time without notice.

