

J-Hanger - SF Series

Product Features

- Size Range: 1½" through 8"
- Material: Carbon steel
- Finish: Galvanized
- Components: Strap and bolt with nut – assembled.

Certifications

- Approvals: Complies with Federal Specification A-A-1192A (Type 5), ANSI/MSS SP-69 and MSS SP-58 (Type 5).

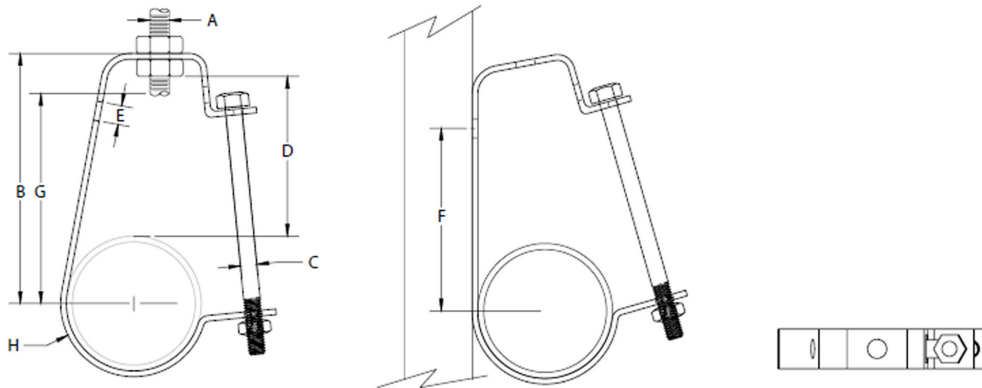

J-Hanger: Loads (LBS) • Weights (LBS) • Dimensions (IN)

Size	✓ To Submit	Part No. Plain	Max Load	Weight	A Rod Size	B	C	D	E	F	G	H Width
1½"		ML36925	400	0.29	3/8	3 ⁹ / ₁₆	1/4	2 ³ / ₁₆	7/16	2 ⁷ / ₁₆	2 ⁷ / ₈	1
2"		ML36926	400	0.31	3/8	3 ¹¹ / ₁₆	1/4	2 ¹ / ₈	7/16	2 ⁹ / ₁₆	3 ¹ / ₁₆	1
3"		ML36927	500	0.78	1/2	4 ¹³ / ₁₆	3/8	2 ⁹ / ₁₆	9/16	3 ¹ / ₂	4 ¹ / ₁₆	1¼
4"		ML36928	500	1.39	5/8	6 ¹ / ₈	3/8	3 ³ / ₁₆	9/16	4 ⁵ / ₈	5 ³ / ₁₆	1¼
6"		ML36929	600	2.26	3/4	7 ³ / ₄	3/8	3 ⁹ / ₁₆	9/16	5 ¹³ / ₁₆	6 ⁵ / ₈	1¼
8"		ML36930	600	4.15	3/4	10 ⁷ / ₁₆	3/8	5 ³ / ₄	9/16	8 ¹ / ₄	9 ¹⁵ / ₁₆	2

Warranty

See warranty information for more details

All dimensions listed are nominal. MAINLINE® reserves the right to make product and material changes at any time without notice.

