

High Efficiency Integral Trap Privacy Urinal

Product Features

- 0.5 GPF (1.9 LPF) High Efficiency or 1.0 GPF (3.8 LPF) Standard Urinal
- 0.5 GPF (1.9 LPF) High Efficiency contributes toward LEED
- Washout Flush Action
- ADA Compliant when Rim is no higher than 17" from finished floor
- Extended sides for Privacy
- Flushing Rim
- Mounting Hardware Included
- Integral Trap
- Flush Valve not included



Overall Dimensions & Weight

- 19"(W) x 13-1/4"(D) x 27-1/4"(H)
- 60 lbs

Certifications

- IAPMO cUPC
- US EPA WaterSense
- ASME A112.19.2
- CSA B45.1-2008

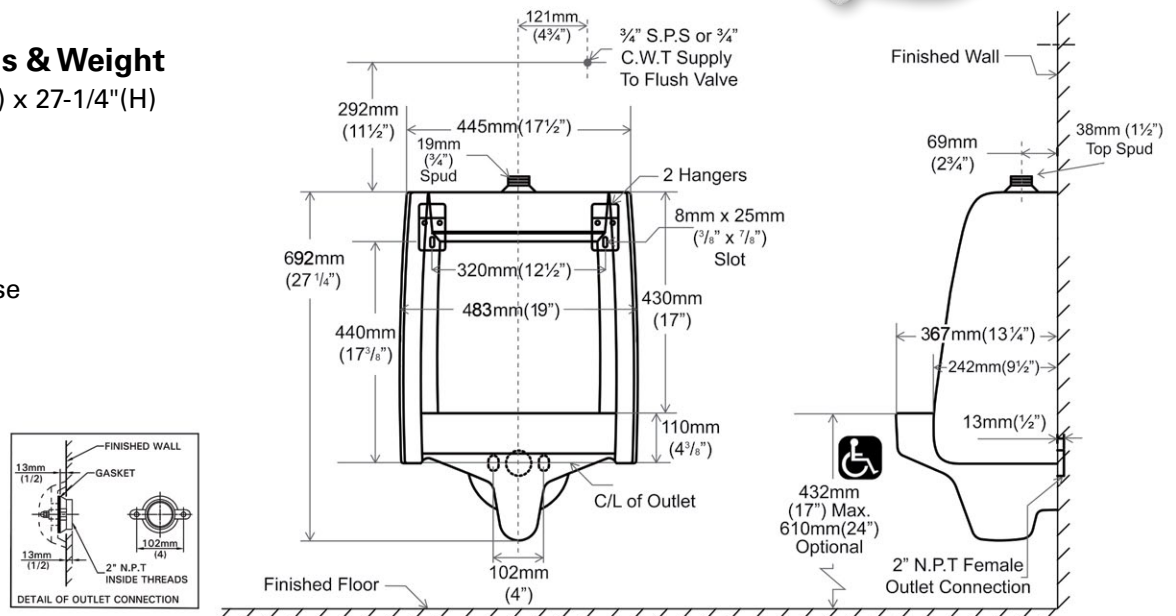

✓ To Submit	Part No.	Description
	MLS10413	High Efficiency Integral Trap Privacy Urinal

Warranty

1 Year Limited Warranty. See warranty information for more details.

All dimensions listed are nominal. MAINLINE® reserves the right to make product and material changes at any time without notice.

Contact your sales representative for more information or visit our website at mainlinecollection.com

