

Brass Gate Valves - Solder



PRODUCT FEATURES

- Sizes Range From 1/2" - 2"
- 200# WOG
- Brass Body
- Inserted Bonnet
- Solder Ends
- Non-Rising Stem
- Solid Disc
- 200 PSI max pressure to 350° F max temperature

MATERIALS & SPECIFICATIONS

Item	Description	Material	Specification	
			Standard	ULL
1	Wheel Nut	Steel	A36	A36
2	Name Plate	Aluminum	-	B85
3	Handwheel	Aluminum	-	B85
4	Stem	Brass	B124	CW510L
5	Gland Nut	Brass	B124	BS2874 CZ122
6	Gland	Brass	B124	CW510L
7	Packing	PTFE	-	WRAS approved
8	Bonnet	Brass	B584 C85400	CW510
9	Lock Nut	Brass	B124	-
10	Gasket	PTFE	-	-
11	Wedge Disc	Brass	B124	CW510L
12	Body	Brass	B584 C85400	CW510L

Pressure/Temperature Ratings	
200# WOG	350° F max temp.

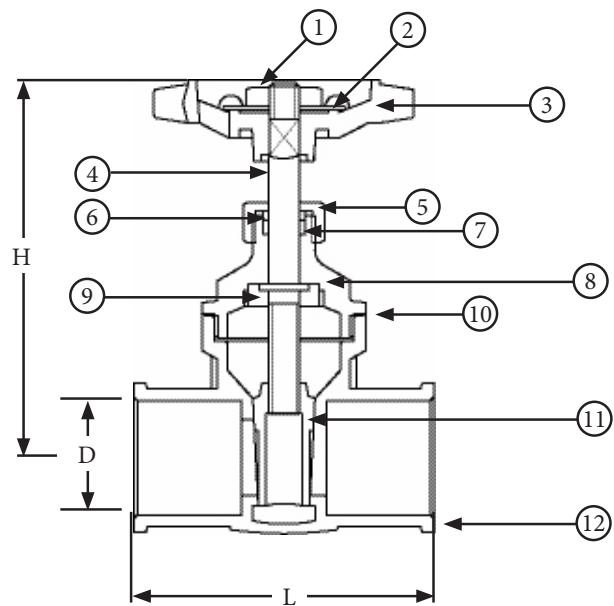

✓ To Submit	Part No.	Length	D	H	L	Weight (lbs.)	
	ML10077	1/2"	0.50	2.75	1.60	0.44	
	ML10078	3/4"	0.68	3.15	2.00	0.69	
	ML10079	1"	0.90	3.62	2.28	1.00	
	ML10080	1 1/4"	1.10	4.37	2.91	1.50	
	ML10081	1 1/2"	1.37	4.84	3.18	2.00	
	ML10082	2"	1.73	5.43	3.62	3.50	
	ML11543	1/2"	0.51	2.79	1.97	0.53	
	ML11544	3/4"	0.74	3.17	2.12	0.82	
	ML11545	1"	1.00	3.93	2.44	1.17	
	ML11546	1 1/4"	1.25	4.37	2.75	1.83	
	ML11547	1 1/2"	1.50	4.94	2.84	2.38	
	ML11548	2"	2.00	6.27	3.23	4.03	

Denotes product is Ultra Low Lead - AB1953 compliant

Warranty

See warranty information for more details

All dimensions listed are nominal. MAINLINE® reserves the right to make product and material changes at any time without notice.

