

High Efficiency Elongated Flush Valve Bowl



Product Features

- 1.28 GPF (4.86 LFP) High Efficiency or 1.6 GPF (6.08 LFP) Standard Bowl
- 1.28 GPF (4.86 LFP) High Efficiency contributes toward LEED
- Elongated Bowl
- 10" (254mm) Rough-in
- 2" Fully Glazed Trapway
- Siphon Jet Flush Action
- Flush Valve & Toilet Seat not included
- Use Seasons Toilet Seat SE10052

Overall Dimensions

- 15"(W) x 27-3/4"(D)

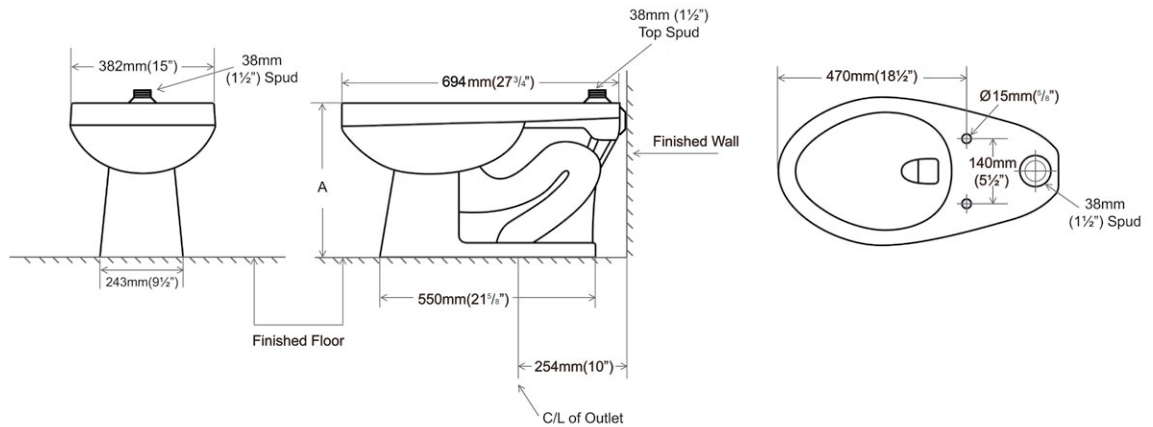

Certifications

- IAPMO cUPC
- ASME A112.19.2
- CSA B45.1-2008

✓ To Submit	Part No.	Description	A	Weight	MaP Score
	MLS10410	Standard Height Bowl	15" (382 mm)	46lbs	850g
	MLS10411	ADA Height Bowl	16-1/2" (419 mm)	50lbs	800g

Warranty

1 Year Limited Warranty. See warranty information for more details.



All dimensions listed are nominal. MAINLINE® reserves the right to make product and material changes at any time without notice.

Contact your sales representative for more information or visit our website at mainlinecollection.com